



# Culvert Permit Application

Page 1 of 2

Updated **APR 2025**

## NOTICE TO APPLICANTS

If 32 feet and under in length, attach a drawing (by hand, not to scale) showing location. If 32 feet or over in length, permit must have stamped engineering drawing showing cleanouts attached. Inspections may be scheduled at [www.pooler-ga.gov](http://www.pooler-ga.gov).

It is essential that all contractors fully comply with the "Call Before You Dig" law by contacting 811 before beginning any digging activities. Additionally, contractors must contact Georgia 811 for a line locate before proceeding with culvert installation.

Before installing any culverts, the contractor must possess a valid utility contractor's license. A city inspector from the Stormwater Department is required to verify the location of utilities on-site before installation can begin. A follow-up inspection is also mandatory before covering the trench to confirm a sealed connection and ensure the use of appropriate bedding materials.

Please note that only reinforced concrete pipe (RCP) is approved for use; plastic or PVC (HDPE) pipe is strictly prohibited. The minimum pipe diameter required by ordinance is fifteen (15) inches, though a larger diameter may be necessary depending on the specific installation area.

Once the culverts are installed, it is the homeowner's responsibility to maintain and repair them, as the city does not assume liability for these tasks.

## OFFICE USE ONLY

Special Conditions: \_\_\_\_\_ Permit Fee: \_\_\_\_\_

Approved by: \_\_\_\_\_ Date Approved: \_\_\_\_\_

## Owner Information

Project Address

Owner Name

Mailing Address

Email

Phone

## Project Information

Description Including Length & Diameter



# Culvert Permit Application

Page 2 of 2

Updated **APR 2025**

---

Location

Projected Construction Date

## Affidavit

By signing below, I acknowledge that I am the owner/property manager, have read and understand the Notice to Applicants, and accept all responsibility pertaining to this request:

---

Applicant Name

Applicant Signature

Date

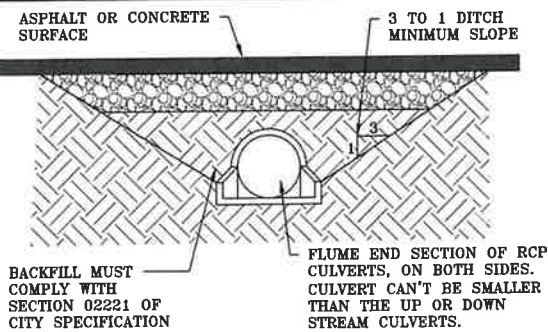

**CULVERT END SECTION**

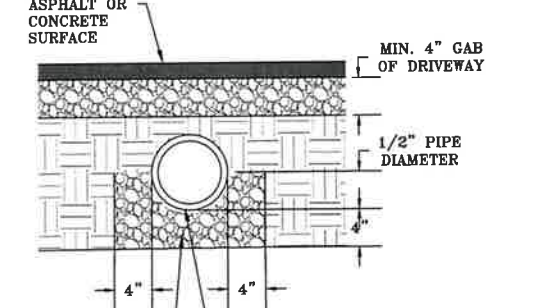

**CROSS-SECTION A-A**

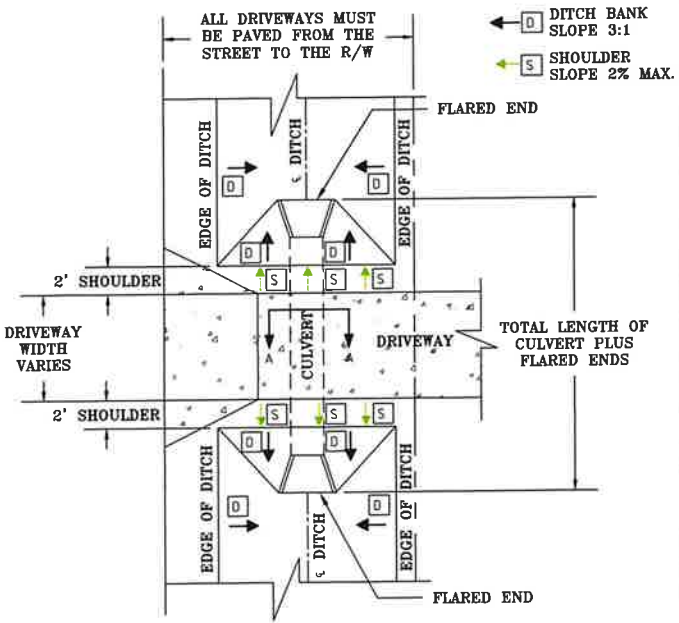

- NOTE:
1. MINIMUM SEPARATION BETWEEN THE BOTTOM OF THE CULVERT AND ANY UTILITY LINE MUST BE 18".
  2. IN THE AREA WHERE CULVERT IS GOING TO BE INSTALLED AND UTILITIES WERE LOCATED, THE CONTRACTOR MUST HAND DIG IN THE AREA TO AVOID ANY DAMAGE TO EXISTING UTILITIES.



**CITY OF POOLER  
2024 STANDARD DETAIL  
RESIDENTIAL DRIVEWAY  
CULVERT LAYOUT**

DONE BY: EOM  
CHECKED BY: J. W.  
SCALE: N.T.S.  
DATE: APRIL, 2024

**P-33**